

# **ZigBee OEM Module**

## **ProBee-ZE10**

### **Datasheet**

**Sena Technologies, Inc.**

**Rev 1.0.1**

## **ProBee-ZE10 Datasheet**

### **Copyright**

Copyright 2011 Sena Technologies, Inc. All rights reserved.

Sena Technologies reserves the right to make changes and improvements to its product without providing notice.

### **Trademark**

ProBee™ is a trademark of Sena Technologies, Inc.

### **Notice to Users**

When a system failure may cause serious consequences, protecting life and property against such consequences with a backup system or safety device is essential. The user agrees that protection against consequences resulting from system failure is the user's responsibility.

This device is not approved for life-support or medical systems.

Changes or modifications to this device not explicitly approved by Sena Technologies will void the user's authority to operate this device.

# Contents

<b>1</b>	<b>General</b>	<b>4</b>
1.1	About This Document.....	4
1.2	Overview.....	4
1.3	Device Diagram .....	5
1.4	Pin Diagram .....	6
1.5	Pin Descriptions .....	6
1.6	Mechanical Drawings .....	8
1.7	Recommended PCB Layout .....	9
<b>2</b>	<b>Electrical Characteristics</b>	<b>10</b>
2.1	Absolute Maximum Ratings.....	10
2.2	Recommended Operating Conditions.....	10
2.3	Power Consumptions .....	10
2.4	Digital I/O Specifications.....	11
2.5	ADC Specifications .....	11
<b>3</b>	<b>RF Characteristics</b>	<b>12</b>
3.1	Transmitter Characteristics.....	12
3.2	Receive Characteristics.....	12
<b>4</b>	<b>Device Terminal Descriptions</b>	<b>13</b>
4.1	UART Mode .....	13
4.2	Reset.....	13
4.3	GPIO .....	14
4.4	SIF.....	14
<b>5</b>	<b>Application Schematics</b>	<b>15</b>
<b>6</b>	<b>Contact Information</b>	<b>17</b>

# 1 General

## 1.1 About This Document

This document provides detail information and specifications of the ProBee-ZE10 ZigBee OEM module. This document does not provide software and usage guide of the ZE10. For more information on the software and usage guide, please refer to the separate ProBee-ZE10 Users Guide.

## 1.2 Overview

The ProBee-ZE10 is an all-in-one ZigBee OEM module with integrated ZigBee core and radio/antenna circuits together with high level software library. Using the ZE10, OEM manufacturers can easily and cost-effectively integrate ZigBee functionality into target products in timely manner.

The ZE10 OEM module is designed to meet specific requirements of low cost and low power wireless applications such as home automation or smart energy by adopting the ZigBee technology. The ZE10 is based on the Ember EM250 ZigBee core and fully certified under the latest ZigBee Pro 2007 standard for the maximum compatibility.

Despite of its low cost and low power consumptions, the ZE10 provides high performance and robust data transfer capability for wide range of applications. The ZE10 can transfer data at up to 250 kbps and reach up to 1.6 km (1 miles) outdoor line-of-sight.

### Key Features

- Integrated 2.4GHz, IEEE 802.15.4-compliant transceiver
- ZigBee 2007 Pro Certified
- ZigBee core: Ember EM250
- Transmit Power: +20dBm E.I.R.P (max.)
- Receiver Sensitivity: -102dBm @1% BER
- TX Current: 190mA @3.3V (max.)
- RX Current: 45mA @3.3V (max.)
- Sleep Current:  $\leq 2\mu\text{A}$
- Working Distance: 1.6 km (1 miles)
- Various Antenna/Connector Options: Dipole 1/3/5dBi, U.FL, Chip
- UART Signals Support: UART\_TXD/RXD, RTS/CTS, DTR/DSR
- 4 Analog Inputs
- 13 Digital Inputs/Outputs
- RoHS Compliant

## Applications

- Advanced Metering Infrastructure
- Home Area Networks (HAN)
- Neighborhood Area Networks (NAN)
- Home Automation
- Advanced lighting, entertainment, and climate control systems
- Service-based monitoring, security, and awareness systems
- Commercial Building Automation
- Climate & lighting control systems
- Industrial and Domestic Applications

## 1.3 Device Diagram

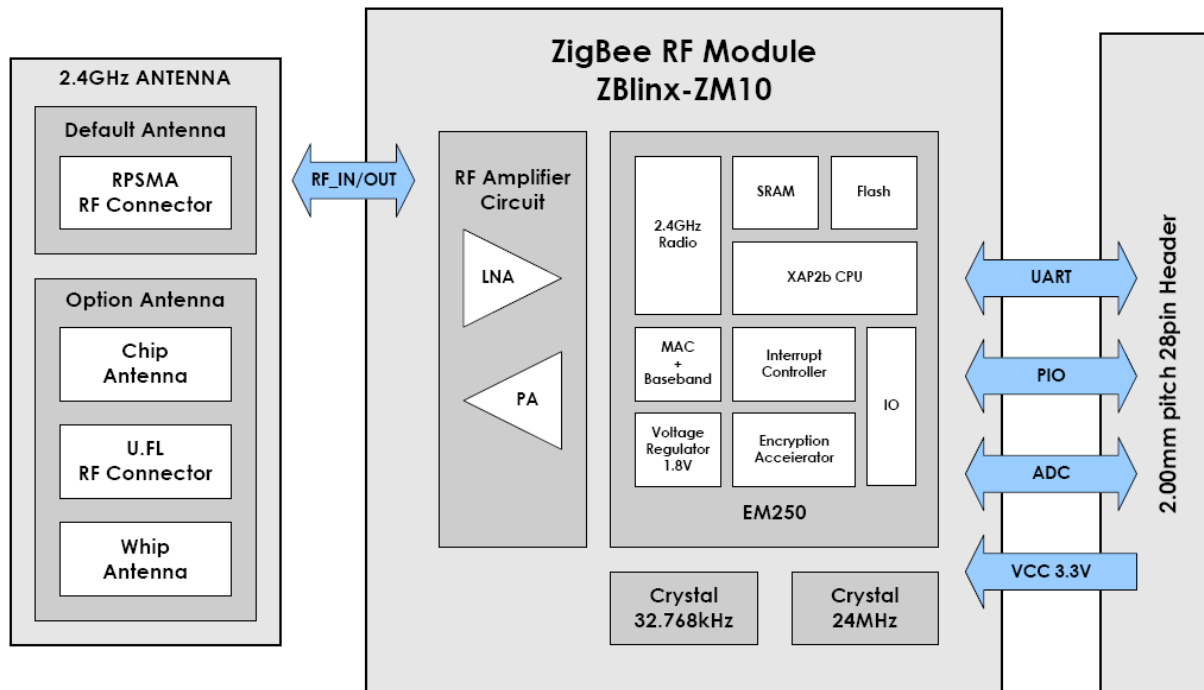

Figure 1-1 Device Diagram

## 1.4 Pin Diagram

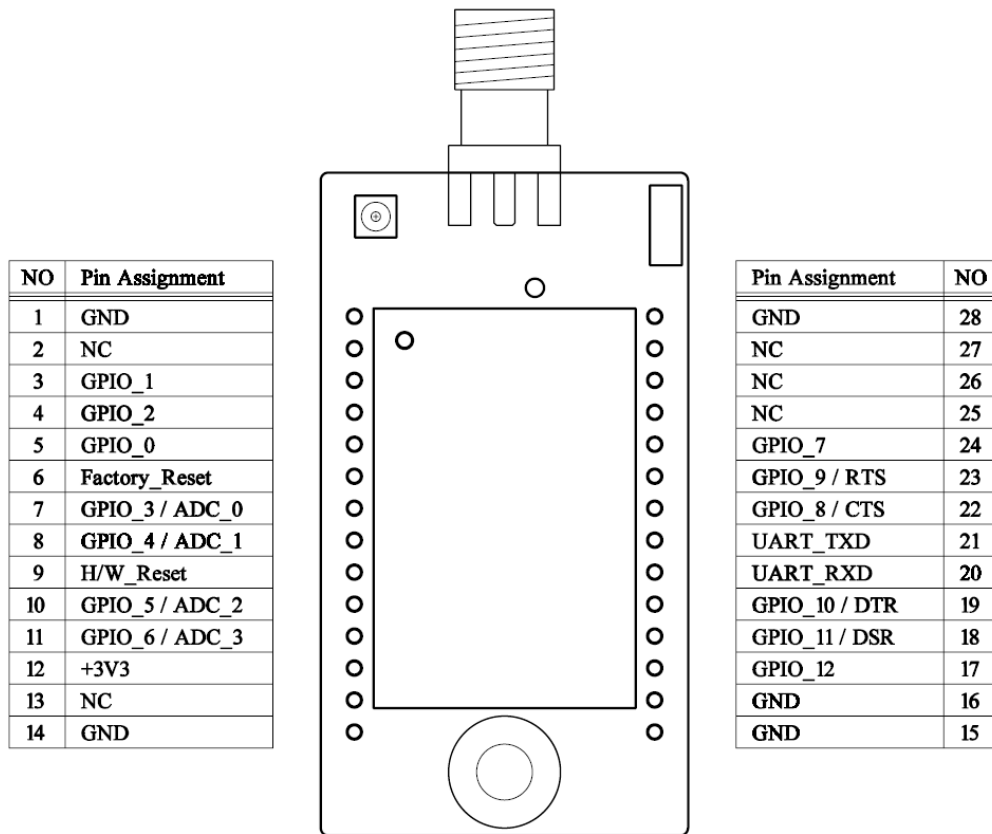

Figure 1-2 Pin Diagram

## 1.5 Pin Descriptions

Table 1-1 Pin Descriptions

Pin	NAME	Default Function	Direction	Description
1	GND	-	-	Ground
2	NC	-	-	Not Connect
3	GPIO_1	DIO_1	IN/OUT	Digital I/O, Power LED
4	GPIO_2	DIO_2	IN/OUT	Digital I/O, Status LED
5	GPIO_0	DIO_0	IN/OUT	Digital I/O, Permit joining input
6	Factory Reset	Factory Reset	IN	Digital I/O, Factory reset input
7	GPIO_3	DIO_3	IN/OUT	Digital I/O / ADC_0
8	GPIO_4	DIO_4	IN/OUT	Digital I/O / ADC_1

<b>9</b>	H/W_/Reset	-	IN	Reset, Active low, > 5ms to cause a reset
<b>10</b>	GPIO_5	DIO_5	IN/OUT	Digital I/O / ADC_2
<b>11</b>	GPIO_6	DIO_6	IN/OUT	Digital I/O / ADC_3
<b>12</b>	+3V3	-	IN	Power supply for system, 3.3V
<b>13</b>	NC	-	-	Not Connect
<b>14</b>	GND	-	-	Ground
<b>15</b>	GND	-	-	Ground
<b>16</b>	GND	-	-	Ground
<b>17</b>	GPIO_12	DIO_12	IN/OUT	Digital I/O
<b>18</b>	GPIO_11	DIO_11	IN/OUT	Digital I/O, UART_DSR
<b>19</b>	GPIO_10	DIO_10	IN/OUT	Digital I/O, UART_DTR
<b>20</b>	UART_RXD	UART_RXD	IN	UART Data Input
<b>21</b>	UART_TXD	UART_TXD	OUT	UART Data Output
<b>22</b>	GPIO_8	DIO_8	IN/OUT	Digital I/O, UART_CTS
<b>23</b>	GPIO_9	DIO_9	IN/OUT	Digital I/O, UART_RTS
<b>24</b>	GPIO_7	DIO_7	IN/OUT	Digital I/O
<b>25</b>	NC	-	-	Not Connect
<b>26</b>	NC	-	-	Not Connect
<b>27</b>	NC	-	-	Not Connect
<b>28</b>	GND	-	-	Ground

### 1.6 Mechanical Drawings

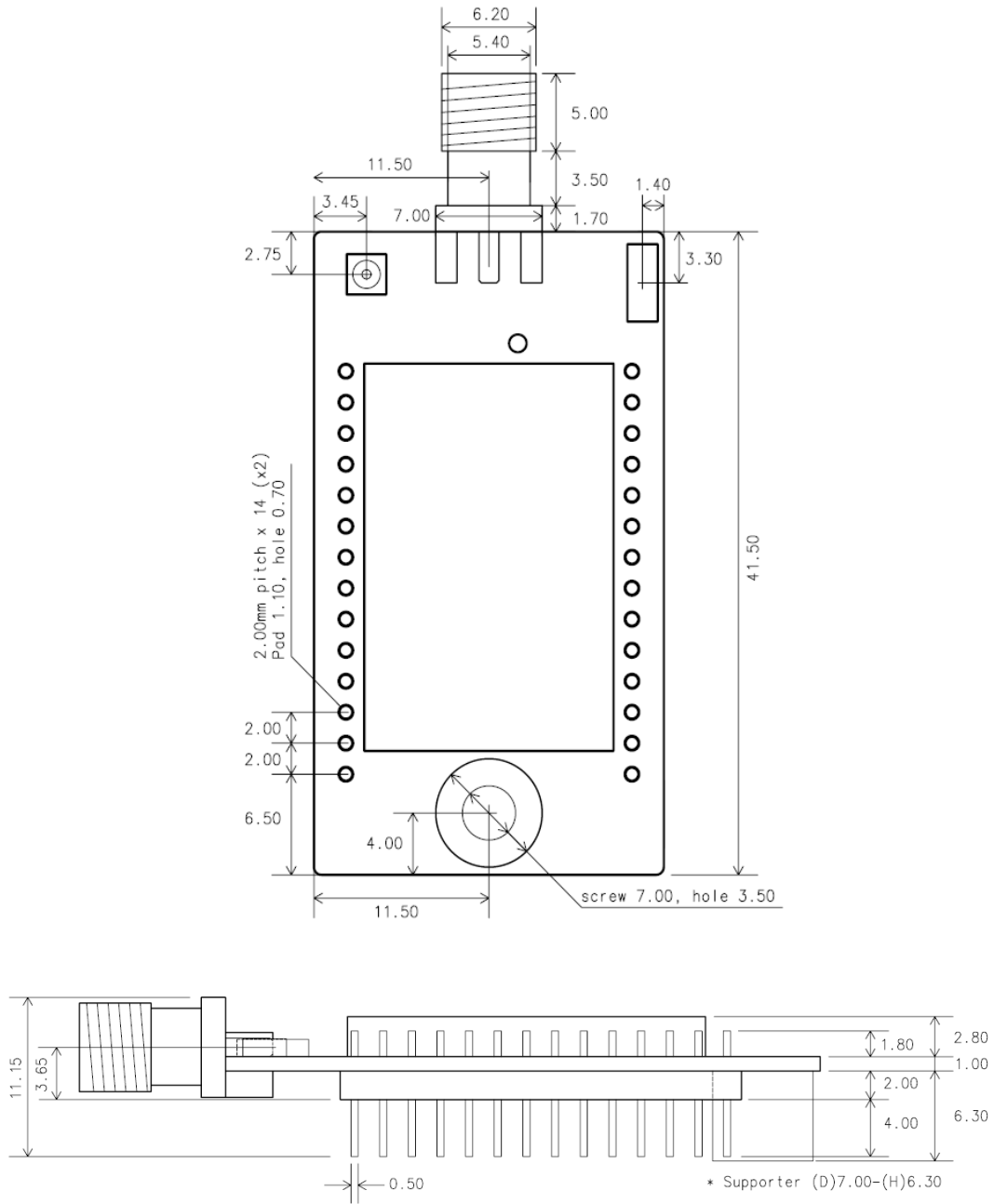

Figure 1-3 Mechanical Drawings

## 1.7 Recommended PCB Layout

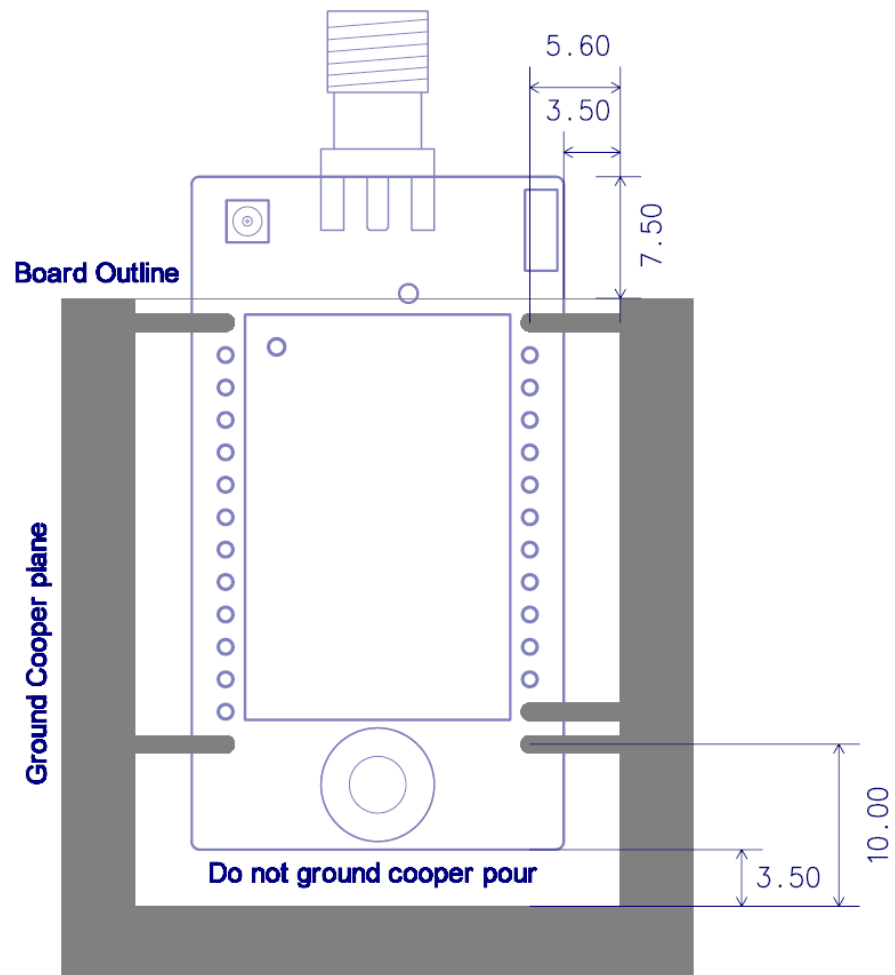

Figure 1-4 Recommended PCB Layout

## 2 Electrical Characteristics

### 2.1 Absolute Maximum Ratings

Table 2-1 Absolute Maximum Ratings

Ratings		Min	Max	Unit
Storage Temperature		-40	+80	°C
Operating Temperature		-40	+80	°C
Supply voltage	VCC	-0.3	3.6	V
	GPIO INPUT	-0.3	3.6	V
	ADC INPUT	-	1.21	V
Other terminal voltages		GND – 0.3	VCC + 0.3	V

### 2.2 Recommended Operating Conditions

Table 2-2 Recommended Operating Conditions

Ratin		Min	Typ	Max	Unit
Operating Temperature		-30	25	+70	°C
Supply voltage	VCC	3.0	3.3	-	V
	GPIO INPUT	3.0	3.3	-	V
	ADC INPUT	-	1.2	-	V

### 2.3 Power Consumptions

Table 2-3 Power Consumptions

Parameter	Test Conditions (VCC=3.3V, 25°C)	Current	Unit
TX	Transmit max. Boost mode enabled	190	mA
TX	Transmit max. Boost mode disabled	185	mA
TX	Transmit min. Boost mode disabled	55	mA
TX	Transmit max, file transfer @115.2kbps	75	mA
RX	Receive, Boost mode enabled	45	mA
RX	Receive, Boost mode disabled	42	mA
Idle	Not connect, Receiver off	9	mA
Sleep	Interval(Sleep=1000ms, Wake-up=5ms)	2	μA
Power-down	Shutdown-mode	1	μA
Reset	Quiescent, nReset asserted	2	μA

## 2.4 Digital I/O Specifications

Table 2-4 Digital I/O Specifications

Parameter (VCC= 3.3V, 25°C)	Min	Typ.	Max	Unit
Input voltage for logic 0	0		0.66	V
Input voltage for logic 1	2.64		3.3	V
Input current for logic 0			-0.5	μA
Input current for logic 1			0.8	μA
Input pull-up resistor value		30		kΩ
Input pull-down resistor value		30		kΩ
Output voltage for logic 0	0		0.6	V
Output voltage for logic 1	2.7		3.3	V
Output source current, GPIO[0:12]			4	mA
Output source current, GPIO[13:16]			8	mA
Output sink current, GPIO[0:12]			4	mA
Output sink current, GPIO[13:16]			8	mA

## 2.5 ADC Specifications

Table 2-5 ADC Specifications

Parameter (VCC= 3.3V, 25°C)	Min	Typ.	Max	Unit
VREF	1.19	1.2	1.21	V
VREF output current			1	mA
VREF load capacitance			10	nF
Minimum input voltage	0			V
Maximum input voltage			VREF	V
Single-ended signal range			VREF	V
Differential signal range	-VREF		+VREF	
Common mode range	0		VREF	
Input referred ADC offset	-10		10	mV
Input Impedance	When taking a Sample	1		MΩ
	When not taking a Sample	10		

## 3 RF Characteristics

### 3.1 Transmitter Characteristics

Table 3-1 Transmitter Characteristics (VCC = 3.3V, 25°C)

Parameter	Test Conditions	Min	Typ	Max	Unit
Frequency range*		2410		2475	MHz
Maximum output power	Boost mode enabled		18		dBm
Minimum output power	Boost mode disabled		-25		dBm
Error vector magnitude			5	15	%
Carrier frequency error		-40		+40	ppm

\* Frequency range: Channel number 14ch (0x0c, 0x0d, 0x0e ..... 0x17, 0x18, 0x19)

### 3.2 Receive Characteristics

Table 3-2 Receive Characteristics (VCC = 3.3V, 25°C)

Parameter	Test Conditions	Min	Typ	Max	Unit
Frequency range		2410		2475	MHz
Sensitivity	1% PER, 20byte packet defined by IEEE 802.15.4		-102		dBm
ACR - High-side	IEEE 802.15.4 signal at -82dBm		35		dB
ACR - Low-side		-	35		dB
ACR - 2 <sup>nd</sup> High-side		-	43		dB
ACR - 2 <sup>nd</sup> Low-side		-	43		dB
Channel rejection for all other channels		-	40		dB
802.11g rejection centered at +12Mhz or 13MHz		-	35		dB
Maximum input signal level for correct Operation (low gain)		0			dBm
Image suppression		-	30		dB
Relative frequency error(2x40ppm required by IEEE 802.15.4)	IEEE 802.15.4 signal at -82dBm	-120		+120	ppm
Relative timing error (2x40ppm required by IEEE 802.15.4)		-120		+120	ppm
Linear RSSI range		40			dB
RSSI Range		-90		-30	dB

## 4 Device Terminal Descriptions

### 4.1 UART Mode

The SC1 UART controller is enabled with SC1\_MODE set to 1.

The UART mode contains the features as shown in the Table 4-1.

Table 4-1 Possible UART Settings

Parameter		Possible Values
Baud Rate	Minimum	300 baud (0%Error)
	Maximum	921kbaud (0.16%Error)
Flow Control		RTS/CTS(optional) or None
Parity		None, Odd or Even
Number of Stop Bits		1 or 2
Bits per Channel		7 or 8

The SC1 UART module obtains its reference baud-rate clock from a programmable baud generator. Baud rates are set by a clock division ratio from the 24MHz clock.

Table 4-2 UART Baud Rates

Baud rate (bps)	SC1_UARTPER	SC1_UARTFRAC	Baud Rate Error (%)
300	40000	0	0
4800	2500	0	0
9600	1250	0	0
19200	625	0	0
38400	312	1	0
57600	208	1	-0.08
115200	104	0	0.16
460800	26	0	0.16
921600	13	0	0.16

### 4.2 Reset

When the asynchronous external reset signal, RESETB (pin 4), is driven low for a time greater than 200ns, the ZE10 resets to its default state. An integrated glitch filter prevents noise from causing an inadvertent reset to occur. If the ZE10 is to be placed in a noisy environment, an external LC Filter or supervisory reset circuit is recommended to guarantee the integrity of the reset signal.

When RESETB asserts, all ZE10 registers return to their reset state as defined. In addition, the ZE10 consumes 1.5mA (typical) of current when held in RESET.

### 4.3 GPIO

The ZE10 has 13 multi-purpose GPIO pins that can be configured in a variety of ways. All pins have the following programmable features:

- Selectable input, output, or bi-directional.
- Output can be totem-pole, used as open drain or open source output for wired-OR applications.
- Can have internal pull-up or pull-down.

### 4.4 SIF

SIF is a synchronous serial interface developed by Cambridge Consultants Ltd. It is the primary programming and debug interface of the ZE10. The SIF module allows external devices to read to write memory-mapped registers in real-time without changing the functionality or timing of the XAP2b core.

The ZE10 pins involved in the SIF interface:

- nSIF\_LOAD
- SIF\_CLK
- SIF\_MOSI
- SIF\_MISO
- nRESET

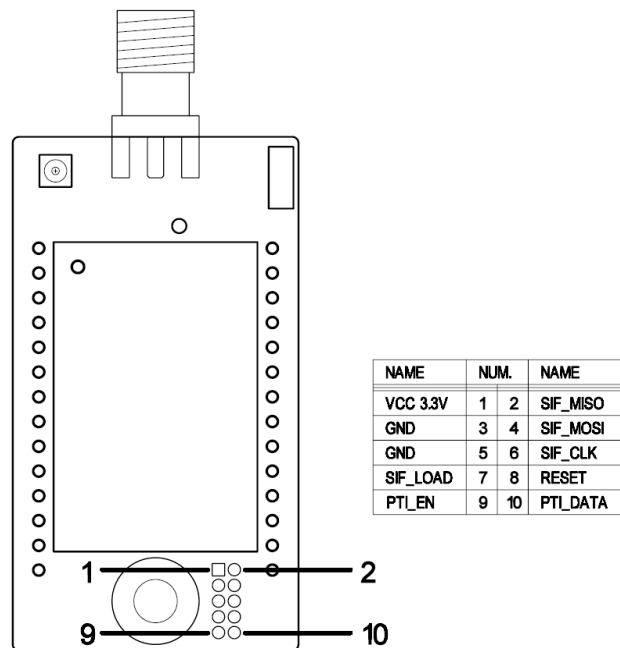

Figure 4-2 SIF Interface Pins

## 5 Application Schematics

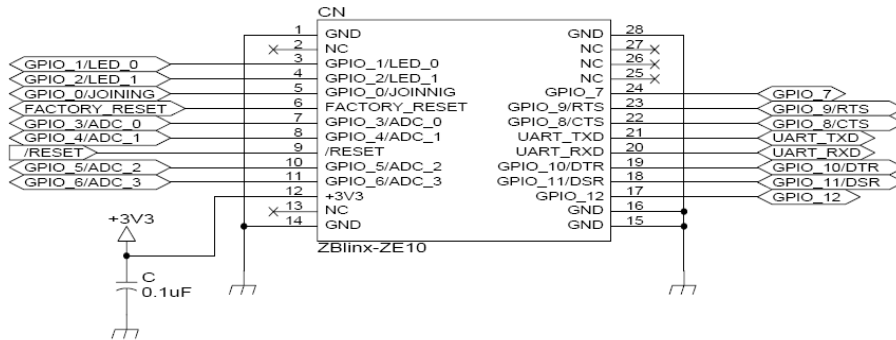

Figure 5-1 ZE10 Interface Connector

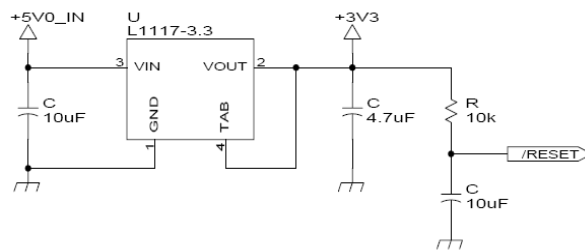

Figure 5-2 Power and POR

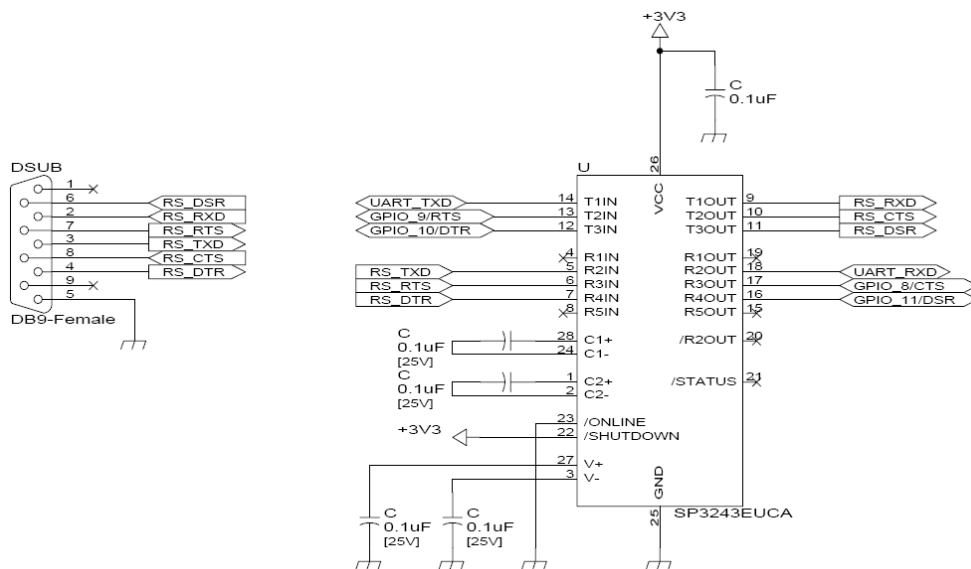

Figure 5-3 RS232 Serial

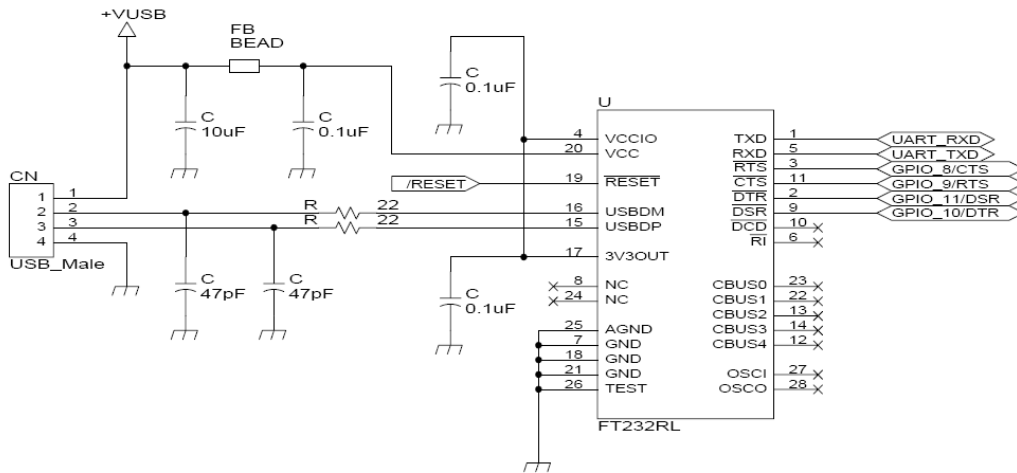

Figure 5-4 USB to UART



Figure 5-5 GPIO Button Input

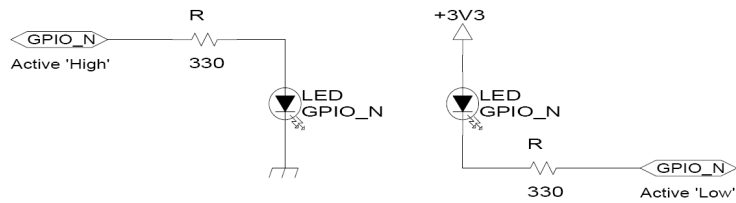

Figure 5-6 GPIO LED Output

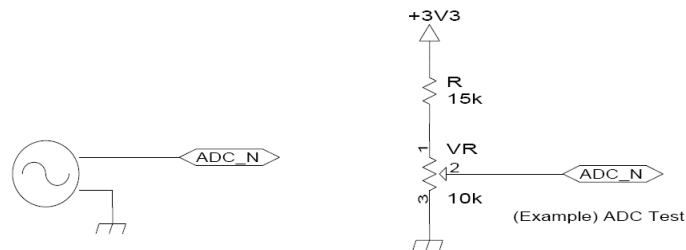

Figure 5-7 ADC VR Input

## 6 Contact Information

### Website

<http://www.sena.com>

### Email

Sales: [sales@sena.com](mailto:sales@sena.com)

Technical Support: [support@sena.com](mailto:support@sena.com)

### U.S. / Canada / South America

3150 Almaden Expressway, Suite 233

San Jose, CA 95118, United States

Toll Free (US/Canada): 8668-US-SENA (866-887-7362)

Main: 408-448-1997

Fax: 408-907-3738

### EU / Africa

12-14 Rond Point des Champs Elysées

75008 Paris, France

Tel: +33 (0)1 53 53 16 29

Fax: +33 (0)1 70 24 70 90

### Asia / Pacific

210 Yangjae-dong, Seocho-gu

Seoul 137-130, Korea (Republic of)

Main: +82-2-571-8283

Sales direct: +82-2-529-7024

Support direct: +82-2-573-5422

Fax: +82-2-573-7710